

**PKA-A18LA & PUZ-A18NKA7(-BS)
18,000 BTU/H WALL MOUNT
18,000 BTU/H HEAT PUMP UNIVERSAL OUTDOOR**



Job Name:

System Reference:

Date:



Indoor Unit.....PKA-A18LA

Outdoor Unit

Standard Model.....PUZ-A18NKA7

Seacoast Model.....PUZ-A18NKA7-BS



INDOOR UNIT FEATURES

- Selectable high sensible vs high latent capacity mode
- UL 60335-2-40 compliant
- Sleek, compact design
- Simple installation
- Airflow direction control
- Auto fan mode
- Suitable for: server rooms, daycare centers, classrooms, churches, small offices, and more
- Multiple control options available:
 - kumo cloud® smart device app for remote access
 - Third-party interface options
 - Wired or wireless controllers

OUTDOOR UNIT FEATURES

- Variable speed INVERTER-driven compressor
- Power receiver pre-charged with refrigerant volume for piping length up to 70 ft
- Low ambient cooling down to 0°F providing 100% capacity
- 24-hour continuous operation (cooling mode)
- High pressure protection
- Fast restart
- Superior energy and operational efficiency

SPECIFICATIONS: PKA-A18LA & PUZ-A18NKA7(-BS)

Cooling at 95°F ¹	Maximum Capacity	BTU/H	18,000
	Rated Capacity	BTU/H	18,000
	Minimum Capacity	BTU/H	5,600
	Maximum Power Input	W	1,680
	Rated Power Input	W	1,680
	Moisture Removal	Pints/h	5.8
	Sensible Heat Factor		0.73
Heating at 47°F ²	Maximum Capacity	BTU/H	22,000
	Rated Capacity	BTU/H	19,000
	Minimum Capacity	BTU/H	5,400
	Maximum Power Input	W	2,150
	Rated Power Input	W	1,640
	Power Factor [208V / 230V]	%	96.7 / 96.7
Heating at 17°F ³	Maximum Capacity	BTU/H	13,600
	Rated Capacity	BTU/H	13,600
	Maximum Power Input	W	1,560
	Rated Power Input	W	1,560
Heating at 5°F ⁴	Maximum Power Input	W	1,110
Efficiency	SEER		19.8
	EER ¹		10.7
	HSPF [IV]		11.2
	COP at 47°F ²		3.4
	COP at 17°F at Maximum Capacity ³		2.5
	ENERGY STAR® Certified		No
Electrical	Voltage, Phase, Frequency		208/230, 1, 60
	Guaranteed Voltage Range	V AC	198 - 253
	Voltage: Indoor - Outdoor, S1-S2	V AC	208/230
	Voltage: Indoor - Outdoor, S2-S3	V DC	24
	Short-circuit Current Rating [SCCR]	kA	5
	Recommended Fuse/Breaker Size (Outdoor)	A	15
	Recommended Wire Size [Indoor - Outdoor]	AWG	14
	Power Supply		Indoor unit is powered by the outdoor unit
Indoor Unit	MCA	A	1.0
	Fan Motor Full Load Amperage	A	0.19
	Fan Motor Type		DC Motor
	Airflow Rate at Cooling, Dry	CFM	265-310-385-455
	Airflow Rate at Cooling, Wet	CFM	215-255-320-375
	Airflow Rate at Heating, Dry	CFM	265-310-385-455
	Sound Pressure Level [Cooling]	dB[A]	34-39-44-48
	Sound Pressure Level [Heating]	dB[A]	34-37-40-43
	Drain Pipe Size	In. [mm]	5/8 [16]
	Condensate Lift Mechanism, Maximum Distance	In. [mm]	19-11/16 [850]
	Coating on Heat Exchanger		—
	External Finish Color		White Munsell 0.7PB 9.2/0.4
	Unit Dimensions	W x D x H: In. [mm]	35-23/64 x 9-11/32 x 11-25/32 [898 x 237 x 299]
	Package Dimensions	W x D x H: In. [mm]	38-3/16 x 13-25/64 x 14-11/64 [970 x 340 x 360]
	Unit Weight	Lbs. [kg]	28 [12.7]
Package Weight	Lbs. [kg]	32 [14.5]	
Indoor Unit Operating Temperature Range	Cooling Intake Air Temp [Maximum / Minimum]*	°F	90 DB, 73 WB / 66 DB, 59 WB
	Heating Intake Air Temp [Maximum / Minimum]	°F	82 DB / 50 DB

NOTES:

AHRI Rated Conditions (Rated data is determined at a fixed compressor speed)	¹ Cooling (Indoor // Outdoor)	°F	80 DB, 67 WB // 95 DB, 75 WB
	² Heating at 47°F (Indoor // Outdoor)	°F	70 DB, 60 WB // 47 DB, 43 WB
	³ Heating at 17°F (Indoor // Outdoor)	°F	70 DB, 60 WB // 17 DB, 15 WB

Select high sensible versus high latent capacity mode via function setting mode 08, "Fan speed" (accessible through Touch MA, Deluxe MA, kumo touch and kumo cloud app control options):

- "High ceiling" mode = high sensible capacity
 - » Mode 08, setting 3 (factory default)
- "Standard" mode = high latent capacity
 - » Mode 08, setting 2

*Outdoor Unit Operating Temperature Range (Cooling Air Temp (Maximum / Minimum)):

- Wind baffles required to operate below 23°F DB in cooling mode.
- Heat pump system with wind baffle: 0°F - 115°F.
- Refer to wind baffle documentation for further information.

**Outdoor Unit Operating Temperature Range (Cooling Thermal Lock-out / Re-start Temperatures; Heating Thermal Lock-out / Re-start Temperatures):

- System cuts out in heating mode to avoid thermistor error and automatically restarts at these temperatures.

SPECIFICATIONS: PKA-A18LA & PUZ-A18NKA7(-BS)

Outdoor Unit	MCA	A	11.0	
	MOCP	A	28	
	Fan Motor Full Load Amperage	A	0.5	
	Airflow Rate [Cooling / Heating]	CFM	1590 / 1590	
	Refrigerant Control		LEV	
	Defrost Method		Reverse Cycle	
	Coating on Heat Exchanger		Blue Fin Coating (BS Model only)	
	Sound Pressure Level, Cooling ¹	dB(A)	44	
	Sound Pressure Level, Heating ²	dB(A)	46	
	Compressor Type		INVERTER-driven twin rotary	
	Compressor Model		SNB130FQCMC-L1	
	Compressor Rated Load Amps	A	7	
	Compressor Locked Rotor Amps	A	12.0	
	Compressor Oil [Type // Charge]	oz.	FV50S // 16	
	External Finish Color		Ivory Munsell 3Y 7.8/1.1	
	Base Pan Heater		N/A	
	Unit Dimensions	W x D x H: In. [mm]	31-13/16 (2+7/16) x 11-13/16 x 24-13/16 [809 (+62) x 300 x 630]	
	Package Dimensions	W x D x H: In. [mm]	37-1/16 x 16-3/16 x 27-7/16 [941 x 411 x 697]	
	Unit Weight	Lbs. [kg]	100 [45]	
	Package Weight	Lbs. [kg]	112 [51]	
	Outdoor Unit Operating Temperature Range	Cooling Air Temp [Maximum / Minimum]*	°F	115 DB / 0 DB
		Heating Air Temp [Maximum / Minimum]	°F	70 DB, 59 WB / 12 DB, 14 WB
		Heating Thermal Lock-out / Re-start Temperatures**	°F	8 / 12
Refrigerant	Maximum Charge Quantity	Lbs, oz	4.0, 14.0	
	Initial Charge Quantity	Ft. [m]	70.0 [21.0]	
	Additional Refrigerant Charge Per Additional Piping Length	oz./Ft. [g/m]	0.2 [19]	
Piping	Gas Pipe Size O.D. [Flared]	In.[mm]	1/2 [12.7]	
	Liquid Pipe Size O.D. [Flared]	In.[mm]	1/4 [6.35]	
	Maximum Piping Length	Ft. [m]	100 [30]	
	Maximum Height Difference	Ft. [m]	100 [30]	
	Maximum Number of Bends		15	

NOTES:

AHRI Rated Conditions

(Rated data is determined at a fixed compressor speed)

¹Cooling (Indoor // Outdoor)

°F 80 DB, 67 WB // 95 DB, 75 WB

²Heating at 47°F (Indoor // Outdoor)

°F 70 DB, 60 WB // 47 DB, 43 WB

³Heating at 17°F (Indoor // Outdoor)

°F 70 DB, 60 WB // 17 DB, 15 WB

Select high sensible versus high latent capacity mode via function setting mode 08, "Fan speed" (accessible through Touch MA, Deluxe MA, kumo touch and kumo cloud app control options):

- "High ceiling" mode = high sensible capacity
 - » Mode 08, setting 3 (factory default)
- "Standard" mode = high latent capacity
 - » Mode 08, setting 2

*Outdoor Unit Operating Temperature Range (Cooling Air Temp (Maximum / Minimum)):

- Wind baffles required to operate below 23°F DB in cooling mode.
- Heat pump system with wind baffle: 0°F - 115°F.
- Refer to wind baffle documentation for further information.

**Outdoor Unit Operating Temperature Range (Cooling Thermal Lock-out / Re-start Temperatures; Heating Thermal Lock-out / Re-start Temperatures):

- System cuts out in heating mode to avoid thermistor error and automatically restarts at these temperatures.

INDOOR UNIT ACCESSORIES: PKA-A18LA

Control Interface	3-Pin Connector	PAC-715AD
	BACnet® and Modbus® Interface	PAC-UKPRC001-CN-1
	IT Extender	PAC-WHS01IE-E
	kumo station® for kumo cloud®	PAC-WHS01HC-E
	Lockdown bracket for remote controller	RCMKP1CB
	Thermostat Interface	PAC-US444CN-1
	Thermostat Interface	PAC-US445CN-1
	USNAP Adapter	PAC-WHS01UP-E
	Wireless Interface for kumo cloud®	PAC-USWHS002-WF-2
Remote Sensor	Flush Mount Remote Temperature Sensor	PAC-USSEN002-FM-1
	Flush Mount Temperature Sensor	PAC-USSEN001-FM-1
	Remote Temperature Sensor	PAC-SE41TS-E
	Wireless temperature and humidity sensor for kumo cloud®	PAC-USWHS003-TH-1
Wired Remote Controller	Deluxe Wired MA Remote Controller†	PAR-40MAAU
	Simple MA Remote Controller†	PAC-YT53CRAU-J
	Touch MA Controller†	PAR-CT01MAU-SB
Wireless Remote Controller	kumo touch™ RedLINK™ Wireless Controller	MHK2
	Wireless MA Remote Controller	PAR-FL32MA-E
Condensate	Blue Diamond (Advanced) Mini Condensate Pump w/ Reservoir & Sensor (208/230V) [recommended]	X87-721
	Blue Diamond (MicroBlue) Mini Condensate Pump (110/208/230V) up to 18,000 BTU/H	X86-003
	Blue Diamond Sensor Extension Cable — 15 Ft.	C13-103
	Drain Pan Level Sensor/Control	SS610E
	Fascia Kit for MicroBlue Pump, mounts the MicroBlue and sensor directly beneath indoor unit	T18-016
	Refco Condensate Pump (100-240 VAC) up to 120,000 BTU/H	COMBI
	Refco Condensate Pump (100-240 VAC) up to 120,000 BTU/H	GOBI-II
	Sauermann Condensate Pump	SI30-230
Disconnect Switch	(30A/600V/UL) [fits 2" X 4" utility box] - Black	TAZ-MS303
	(30A/600V/UL) [fits 2" X 4" utility box] - White	TAZ-MS303W
Drain Hose	Flexible Mini-Split Drain Hose	DRX-16
Lineset	100' x 1/4" x 100' / 1/2" Lineset (Twin-Tube Insulation)	MLS141212T-100
	15' x 1/4" x 15' / 1/2" Lineset (Twin-Tube Insulation)	MLS141212T-15
	30' x 1/4" x 30' / 1/2" Lineset (Twin-Tube Insulation)	MLS141212T-30
	50' x 1/4" x 50' / 1/2" Lineset (Twin-Tube Insulation)	MLS141212T-50
	65' x 1/4" x 65' / 1/2" Lineset (Twin-Tube Insulation)	MLS141212T-65

OUTDOOR UNIT ACCESSORIES: PUZ-A18NKA7(-BS)

Air Outlet Guide	Air Outlet Guide	PAC-SJ07SG-E
Centralized Drain Pan	Centralized Drain Pan	PAC-SG63DP-E
	Drain Pan	PAC-SG64DP-E
Control/Service Tool	Control/Service Tool	PAC-SK52ST
	M- & P-Series Maintenance Tool Cable Set	M21EC0397
	USB/UART Conversion Cable (Required for all laptop connection)	M21EC1397
Drain Socket	Drain Socket	MAC-871DS
Hail Guards	Hail Guard	HG-A5
M-NET Converter	M-NET Converter	PAC-SJ96MA-E
Mini-Split Wire	14 Gauge, 4 wire MiniSplit Cable—250 ft. roll	S144-250
	14 Gauge, 4 wire MiniSplit Cable—50 ft. roll	S144-50
	16 Gauge, 4 wire MiniSplit Cable—250 ft. roll	S164-250
	16 Gauge, 4 wire MiniSplit Cable—50 ft. roll	S164-50
Mounting Pad	Condensing Unit Mounting Pad: 16" x 36" x 3"	ULTRILITE1
Stand	18" Single Fan Stand	QSMS1801M
	24" Single Fan Stand	QSMS2401M
	Condenser Wall Bracket	QSWB2000M-1
	Condenser Wall Bracket - Stainless Steel Finish	QSWBSS
Wind Baffle	Outdoor Unit Stand — 12" High	QSMS1201M
	Front Wind Baffle	WB-PA4
	Rear Wind Baffle	WB-RE4
	Side Advanced Wind Baffle	WB-SD4

OUTDOOR UNIT DIMENSIONS: PUZ-A18NKA7(-BS)

Unit: mm<in>



Free space around the outdoor unit (basic example)

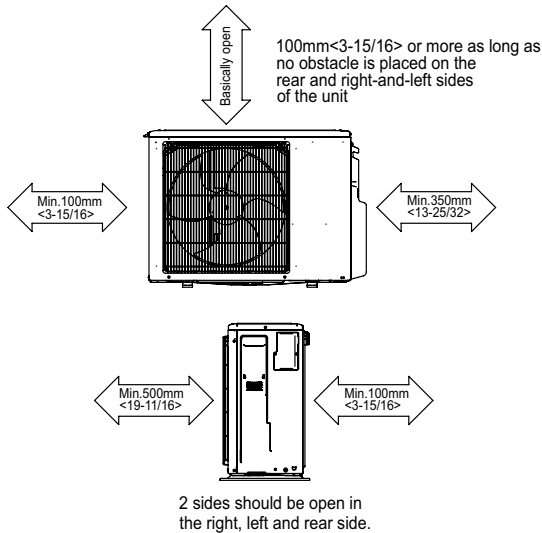

FOUNDATION BOLTS

Please secure the unit firmly with 4 foundation (M10<W3/8>) bolts. (Bolts, washers and nut must be purchased locally).

<Foundation bolt height>

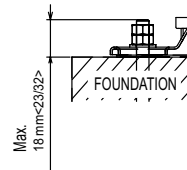

PIPING-WIRING DIRECTION

Piping and wiring connection can be made from the rear direction only.