



Job Name:	
System Reference:	Date:

Indoor Unit: MSZ-GL24NA	Outdoor Unit: <input type="checkbox"/> MUZ-GL24NA-U1 <input type="checkbox"/> MUZ-GL24NA-U2	Wireless Remote Controller
		

GENERAL FEATURES

- Slim wall-mounted indoor units provide zone comfort control
- The outdoor unit powers the indoor unit, and should a power outage occur, the system is automatically restarted when power returns
- INVERTER-driven compressor and LEV provide high efficiency and comfort while using only the energy needed to maintain maximum performance
- Multiple fan speed options: Quiet, Low, Medium, High, Super-high, Auto
- Multiple control options available:
 - Hand-held Remote Controller (provided with unit)
 - kumo cloud® smart device app for remote access
 - Third-party interface options
 - Wired or wireless controllers
- Quiet operation
- Smart Set: recalls a preferred preset temperature setting at the touch of a button
- Blue Fin anti-corrosion treatment applied to the outdoor unit heat exchanger for increased coil protection and longer life

SPECIFICATIONS: MSZ-GL24NA & MUZ-GL24NA

Cooling ¹	Maximum Capacity	BTU/H	31,400	
	Rated Capacity	BTU/H	22,400	
	Minimum Capacity	BTU/H	8,200	
	Maximum Power Input	W	3,522	
	Rated Power Input	W	1,800	
	Moisture Removal	Pints/h	5.1	
	Sensible Heat Factor		0.75	
	Power Factor	%	99 / 99	
Heating at 47°F ²	Maximum Capacity	BTU/H	36,900	
	Rated Capacity	BTU/H	27,600	
	Minimum Capacity	BTU/H	7,500	
	Maximum Power Input	W	3,592	
	Rated Power Input	W	2,340	
	Power Factor	%	99 / 99	
Heating at 17°F ³	Maximum Capacity	BTU/H	24,600	
	Rated Capacity	BTU/H	16,000	
	Maximum Power Input	W	3,232	
	Rated Power Input	W	1,712	
Heating at 5°F ⁴	Maximum Capacity	BTU/H	19,320	
	Maximum Power Input	W	2,990	
Heating at -4°F ⁵	Maximum Capacity	BTU/H	15,450	
Efficiency	SEER SEER2		20.5 20.4	
	EER ¹ EER2 ¹		12.5 12.5	
	HSPF (IV) HSPF2 (IV)		10.0 10.0	
	COP at 47°F ²		3.46	
	COP at 17°F in Maximum Capacity ³		2.23	
	COP at 5°F in Maximum Capacity ⁴		1.89	
	ENERGY STAR® certified units (ENERGY STAR products are third-party certified by an EPA-recognized Certification Body.)		YES	
Electrical	Voltage, Phase, Frequency		208/230V, 1 phase, 60Hz	
	Guaranteed Voltage Range	V AC	187 - 253	
	Voltage: Indoor - Outdoor, S1-S2	V AC	208 / 230	
	Voltage: Indoor - Outdoor, S2-S3	V DC	24	
	Short-circuit Current Rating (SCCR)	kA	5	
	Recommended Fuse/Breaker Size (Outdoor)	A	20	
	Recommended Wire Size (Indoor - Outdoor)	AWG	14	
Indoor Unit	MCA	A	1	
	MOCP	A	20	
	Blower Motor Full Load Amperage	A	0.76	
	Blower Motor Output	W	56	
	Airflow Rate at Cooling, Dry	CFM	738-628-544-469-388	
	Airflow Rate at Cooling, Wet	CFM	661-562-487-420-347	
	Airflow Rate at Heating, Dry	CFM	738-628-544-469-388	
	Sound Pressure Level (Cooling)	dB(A)	53-49-45-41-34	
	Sound Pressure Level (Heating)	dB(A)	52-49-45-41-32	
	Drain Pipe Size	In. (mm)	5/8 (15.88)	
	Heat Exchanger Type		Plate fin coil	
	External Finish Color		Munsell 1.0Y 9.2/0.2	
	Unit Dimensions	W: In. (mm)		43-5/16 (1,100)
		D: In. (mm)		9-3/8 (238)
H: In. (mm)			12-13/16 (325)	

SPECIFICATIONS: MSZ-GL24NA & MUZ-GL24NA

	Package Dimensions	W: In. (mm)	45-1/2 (1,160)
		D: In. (mm)	12-3/4 (320)
		H: In. (mm)	15-1/2 (390)
	Unit Weight	Lbs. (kg)	37 (17)
	Package Weight	Lbs. (kg)	42 (19)
Indoor Unit Operating Temperature Range	Cooling Intake Air Temp (Maximum / Minimum)*	°F	90 DB, 73 WB / 67 DB, 57 WB
	Heating Intake Air Temp (Maximum / Minimum)	°F	80 DB / 70 DB
Outdoor Unit	MCA	A	17.1
	MOCP	A	20
	Fan Motor Full Load Amperage	A	0.93
	Fan Motor Output	W	77
	Airflow Rate	CFM	1,769 / 1,701
	Refrigerant Control		LEV
	Defrost Method		Reverse cycle
	Heat Exchanger Type		Plate fin coil
	Sound Pressure Level, Cooling ¹	dB(A)	55
	Sound Pressure Level, Heating ²	dB(A)	55
	Compressor Type		DC INVERTER-driven
	Compressor Model		SNB172FQKMT
	Compressor Rated Load Amps	A	12.9
	Compressor Locked Rotor Amps	A	16.1
	Compressor Oil Type // Charge	oz.	FV50S // 13.5
	External Finish Color		Munsell 3Y 7.8/1/1
	Base Pan Heater		Optional
	Unit Dimensions	W: In. (mm)	33-1/16 (840)
		D: In. (mm)	13 (330)
		H: In. (mm)	34-5/8 [880]
Package Dimensions	W: In. (mm)	38-9/16 (980)	
	D: In. (mm)	16-9/16 (420)	
	H: In. (mm)	39 (990)	
Unit Weight	Lbs. (kg)	119 [54]	
Package Weight	Lbs. (kg)	138 (63)	
Outdoor Unit Operating Temperature Range	Cooling Air Temp (Maximum / Minimum)*	°F	115 / 14
	Cooling Thermal Lock-out / Re-start Temperatures**	°F	-4 / 0
	Heating Air Temp (Maximum / Minimum)	°F	75 / -4
	Heating Thermal Lock-out / Re-start Temperatures**	°F	-9 / -4
Refrigerant	Type		R410A
	Charge	Lbs, oz	4, 3
Piping	Gas Pipe Size O.D. (Flared)	In. (mm)	5/8 (15.88)
	Liquid Pipe Size O.D. (Flared)	In. (mm)	3/8 (9.52)
	Maximum Piping Length	Ft. (m)	100 (30)
	Maximum Height Difference	Ft. (m)	50 (15)
	Maximum Number of Bends		10

SPECIFICATIONS: MSZ-GL24NA & MUZ-GL24NA

Notes

AHRI Rated Conditions (Rated data is determined at a fixed compressor speed)	¹ Cooling (Indoor // Outdoor)	°F	80 DB, 67 WB // 95 DB, 75 WB
	² Heating at 47°F (Indoor // Outdoor)	°F	70 DB, 60 WB // 47 DB, 43 WB
	³ Heating at 17°F (Indoor // Outdoor)	°F	70 DB, 60 WB // 17 DB, 15 WB
Conditions	⁴ Heating at 5°F (Indoor // Outdoor)	°F	70 DB, 60 WB // 5 DB, 4 WB
	⁵ Heating at -4°F (Indoor // Outdoor)	°F	70 DB, 60 WB // -4 DB, -5 WB

*Applications should be restricted to comfort cooling only; equipment cooling applications are not recommended for low ambient temperature conditions.

**System cuts out in heating mode to avoid thermistor error and automatically restarts at these temperatures.

ACCESSORIES: MSZ-GL24NA

Anti-allergy Enzyme Filter	□ MAC-2310FT-E
kumo touch™ RedLINK™ Wireless Controller	□ MHK2
Deluxe MA Remote Controller ¹	□ PAR-40MAAU
Simple MA Controller ¹	□ PAC-YT53CRAU-J
Touch MA Controller ¹	□ PAR-CT01MAU-SB
Wireless Temperature and Humidity Sensor	□ PAC-USWHS003-TH-1
System Control Interface ²	□ MAC-334IF-E
Wireless Interface 2	□ PAC-USWHS002-WF-2
Thermostat Interface	□ PAC-US444CN-1
Thermostat Interface	□ PAC-US445CN-1
kumo station® for kumo cloud®	□ PAC-WHS01HC-E
USNAP Interface	□ PAC-WHS01UP-E
IT Extender	□ PAC-WHS01IE-E
BACnet® and MODBUS® Interface	□ PAC-UKPRC001-CN-1
Lockdown Bracket for Hand-held Remote Controllers	□ RCMKP1CB
Blue Diamond Sensor Extension Cable — 15 Ft.	□ C13-103
Blue Diamond Alarm Extension Cable — 6.5 Ft.	□ C13-192
Blue Diamond MultiTank — collection tank for use with multiple pumps	□ C21-014
Blue Diamond Rubber Foot Pads	□ F10-010
Mini Condensate Pump — 230 volt application	□ SI30-230
MegaBlue Advanced Blue Diamond Condensate Pump w/ Reservoir & Sensor	□ X87-835 - 110 to 250V
MaxiBlue Advanced Blue Diamond Mini Condensate Pump w/ Reservoir & Sensor (110V) up to 48,000 BTU/H[recommended]	□ X87-711 - 110V
Advanced Blue Diamond Mini Condensate Pump w/ Reservoir & Sensor (208/230V) [recommended]	□ X87-721 - 208/230V
MicroBlue Blue Diamond Mini Condensate Pump (110/208/230V) up to 18,000 BTU/H	□ X85-003
Fascia Kit for MicroBlue Pump – mounts the MicroBlue and sensor directly beneath the indoor unit	□ T18-016
Refco Condensate Pump (100-240 VAC) up to 120,000 BTU/H	□ COMBI
Refco Condensate Pump (100-240 VAC) up to 120,000 BTU/H	□ GOBI-II
Drain Pan Level Sensor	□ SS610E
(30A/600V/UL) [fits 2" X 4" utility box] - Black	□ TAZ-MS303
(30A/600V/UL) [fits 2" X 4" utility box] - White	□ TAZ-MS303W
Flexible Mini-Split Drain Hose	□ DRX-16

¹ Requires MAC-334IF-E

² Allows indoor units to connect to an MA Controller

ACCESSORIES: MUZ-GL24NA

Air Outlet Guide	<input type="checkbox"/> MAC-886SG-E
Drain Socket	<input type="checkbox"/> MAC-860DS
Optional Defrost Heater	<input type="checkbox"/> MAC-642BH-U1
Hail Guard	<input type="checkbox"/> HG-A7
Outdoor Unit 3-1/4 inch Mounting Base (Pair) - Plastic	<input type="checkbox"/> DSD-400P
Condensing Unit Mounting Pad 16" x 36" x 3"	<input type="checkbox"/> ULTRILITE1
Outdoor Unit Stand — 12" High	<input type="checkbox"/> QSMS1201M
Outdoor Unit Stand — 18" High	<input type="checkbox"/> QSMS1801M
Outdoor Unit Stand — 24" High	<input type="checkbox"/> QSMS2401M
Heavy Duty Wall Mounting Bracket— Coated Steel	<input type="checkbox"/> QSWB2000M-1
Heavy Duty Wall Mounting Bracket — 316 Series Stainless Steel	<input type="checkbox"/> QSWBSS
10' x 3/8" x 10' x 5/8" Lineset (Twin-Tube Insulation)	<input type="checkbox"/> MPLS385812T-10
15' x 3/8" x 15' x 5/8" Lineset (Twin-Tube Insulation)	<input type="checkbox"/> MPLS385812T-15
30' x 3/8" x 30' x 5/8" Lineset (Twin-Tube Insulation)	<input type="checkbox"/> MPLS385812T-30
50' x 3/8" x 50' x 5/8" Lineset (Twin-Tube Insulation)	<input type="checkbox"/> MPLS385812T-50
65' x 3/8" x 65' x 5/8" Lineset (Twin-Tube Insulation)	<input type="checkbox"/> MPLS385812T-65
100' x 3/8" x 100' x 5/8" Lineset (Twin-Tube Insulation)	<input type="checkbox"/> MPLS385812T-100

DIMENSIONS: MSZ-GL24NA

Unit: inch

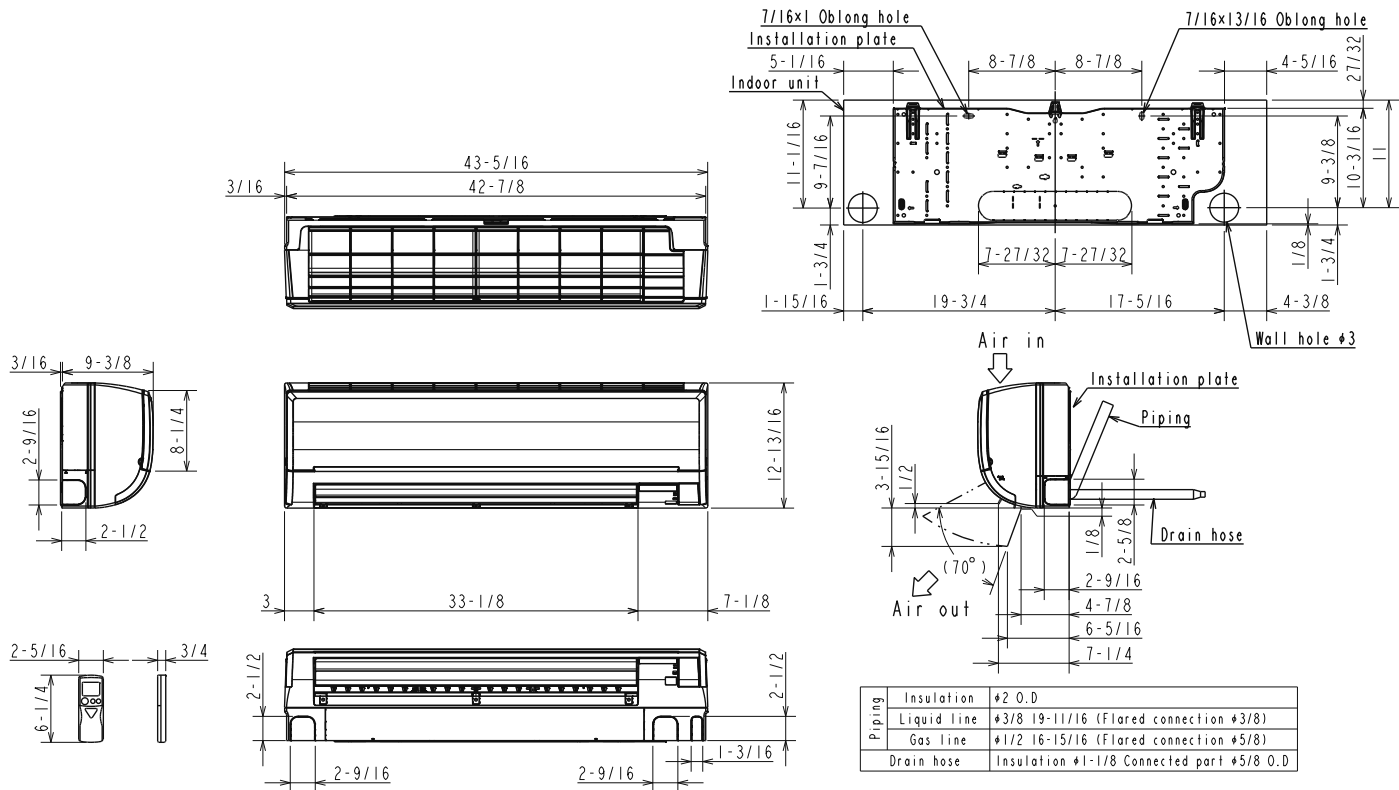

Piping	Insulation	$\#2$ O.D
	Liquid line	$\#3/8$ 19-11/16 (Flared connection $\#3/8$)
	Gas line	$\#1/2$ 16-15/16 (Flared connection $\#5/8$)
Drain hose	Insulation $\#1\text{-}1/8$ Connected part $\#5/8$ O.D	

Unit: inch

REQUIRED SPACE

*1 20 in. or more when front and sides of the unit are clear

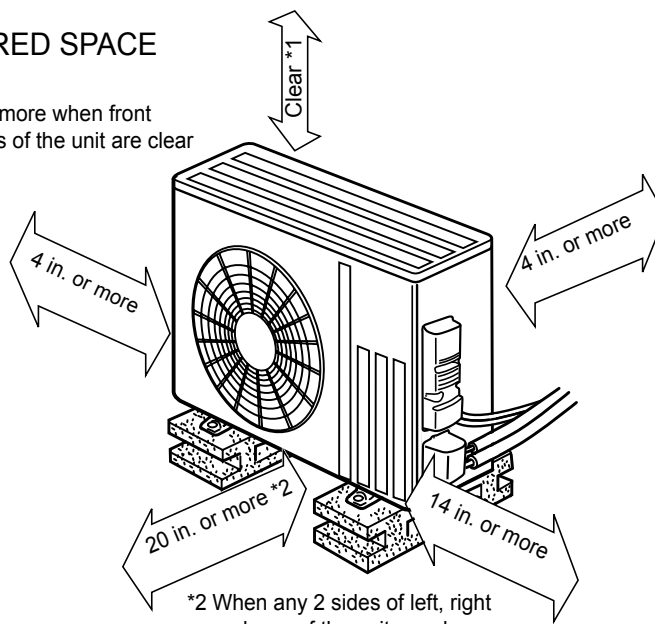
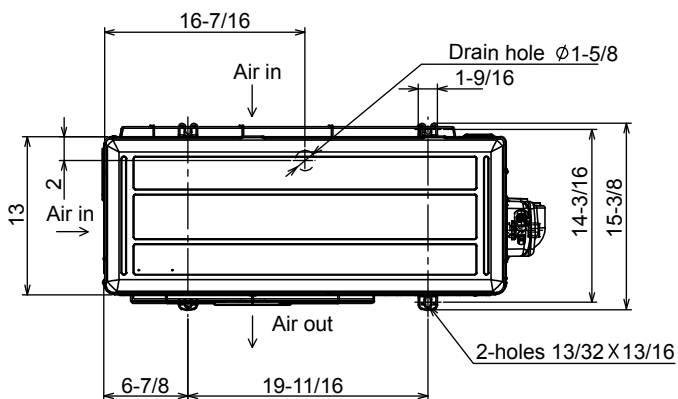

*2 When any 2 sides of left, right and rear of the unit are clear

